



US011738435B1

(12) **United States Patent**
Fulbrook

(10) **Patent No.:** **US 11,738,435 B1**

(45) **Date of Patent:** **Aug. 29, 2023**

(54) **CASING CHISEL SYSTEM**

(71) Applicant: **Efficiency Products, LLC**, Fairfax, VA (US)

(72) Inventor: **Jim E. Fulbrook**, Fairfax, VA (US)

(73) Assignee: **EFFICIENCY PRODUCTS, LLC.**, Fairfax, VA (US)

(*) Notice: Subject to any disclaimer, the term of this patent is extended or adjusted under 35 U.S.C. 154(b) by 4 days.

(21) Appl. No.: **17/537,218**

(22) Filed: **Nov. 29, 2021**

Related U.S. Application Data

(63) Continuation-in-part of application No. 16/922,272, filed on Jul. 7, 2020, now Pat. No. 11,185,973.

(60) Provisional application No. 62/947,572, filed on Dec. 13, 2019.

(51) **Int. Cl.**
B25D 3/00 (2006.01)
A47L 13/10 (2006.01)
B25G 3/12 (2006.01)

(52) **U.S. Cl.**
CPC **B25D 3/00** (2013.01); **A47L 13/10** (2013.01); **B25G 3/12** (2013.01)

(58) **Field of Classification Search**

CPC .. B25G 3/12; B25D 3/00; E04F 21/00; B23D 71/04; B23D 71/06; B23D 71/08; B24B 19/009; B24D 15/02

See application file for complete search history.

(56) **References Cited**

U.S. PATENT DOCUMENTS

6,182,317 B1 2/2001 Huang
6,270,399 B2 8/2001 Gunn
2012/0122379 A1 5/2012 McDonnell et al.
2015/0026986 A1 1/2015 Berglund

Primary Examiner — Joel D Crandall

(74) *Attorney, Agent, or Firm* — Invention To Patent Services; Alex Hobson

(57) **ABSTRACT**

A casing chisel system includes a two-sided casing chisel and one or more detailed chisels. The two-sided casing chisel has two chisel blades that are mirror images of each other to enable one tool for chiseling and cleaning the doorway casing on either side of the doorway. The two-sided tool simply has to be flipped around to allow cleaning of doorway casing on an opposing side of the doorway. The chisel blades may be coupled to a blade assembly that is detachably attachable to a handle assembly. The blade assembly may have a first end and second end each having a two-sided chisel blade or sanding ends with an abrasive material to allow sanding along a doorway casing. The detail chisel may be straight detail chisel having straight chisel blades or a curved detail chisel having curved chisel blades, that may extend in a radius of curvature.

20 Claims, 17 Drawing Sheets

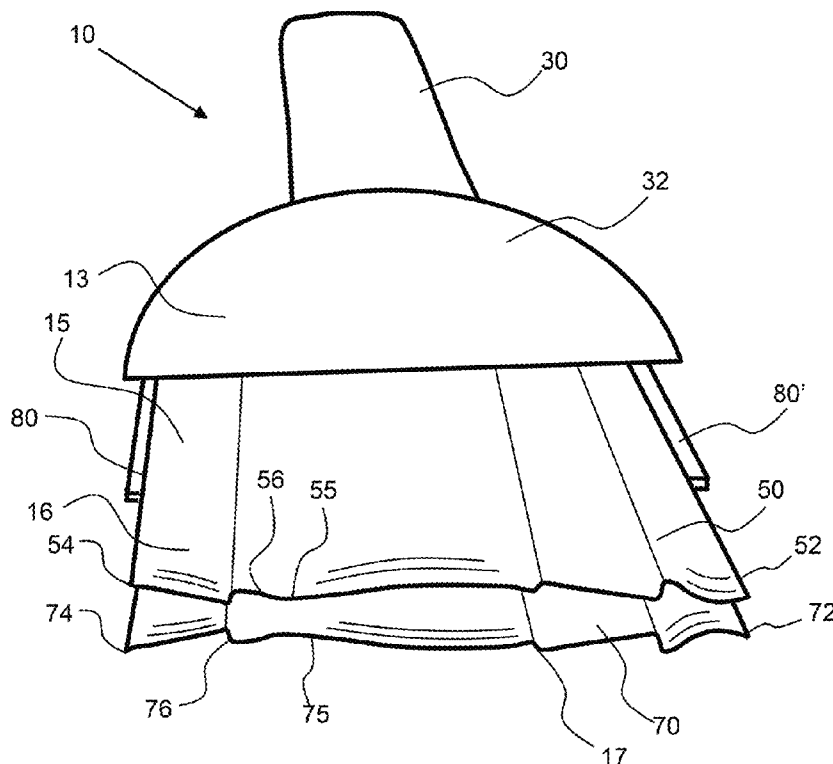

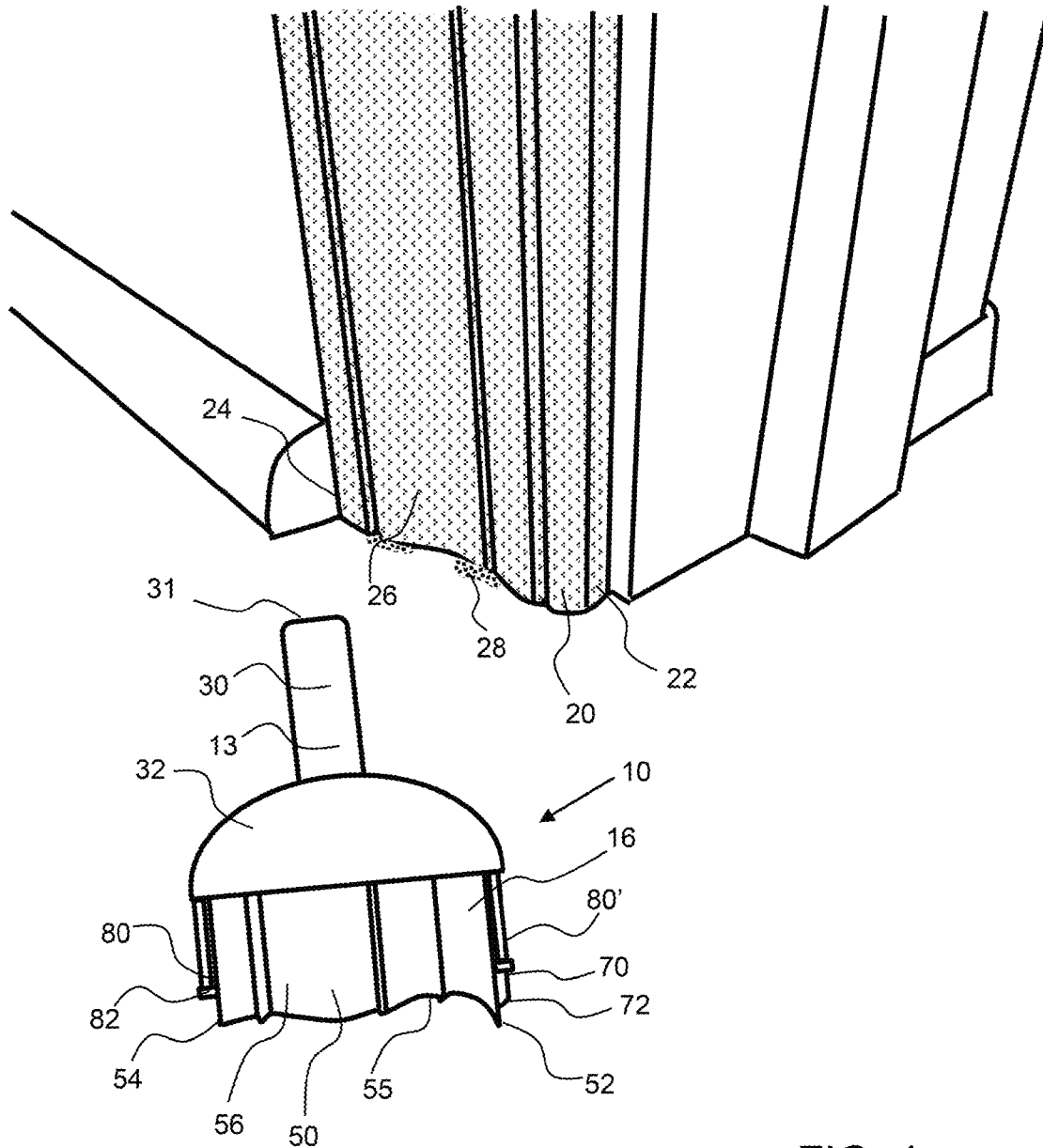

FIG. 1

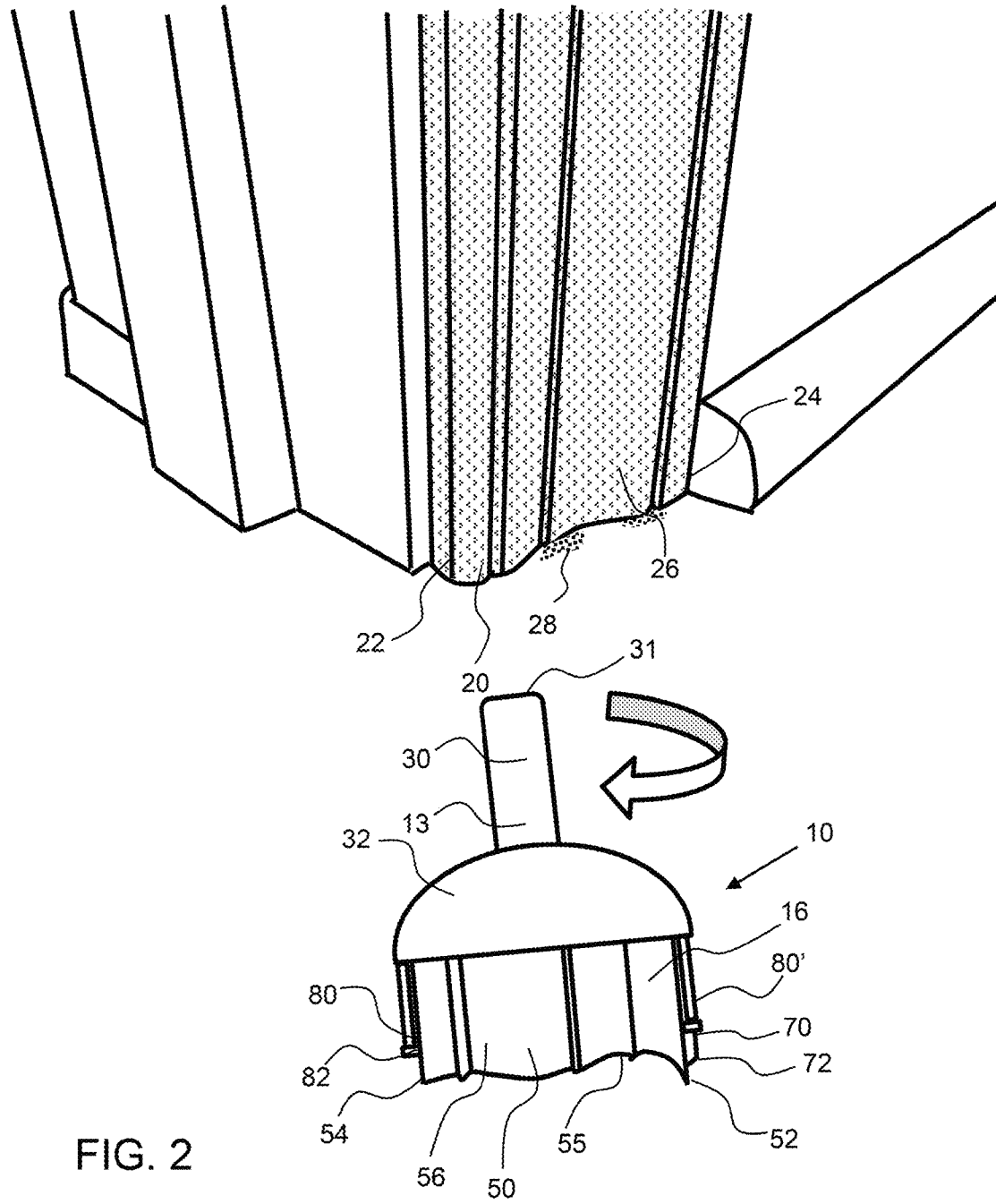

FIG. 2

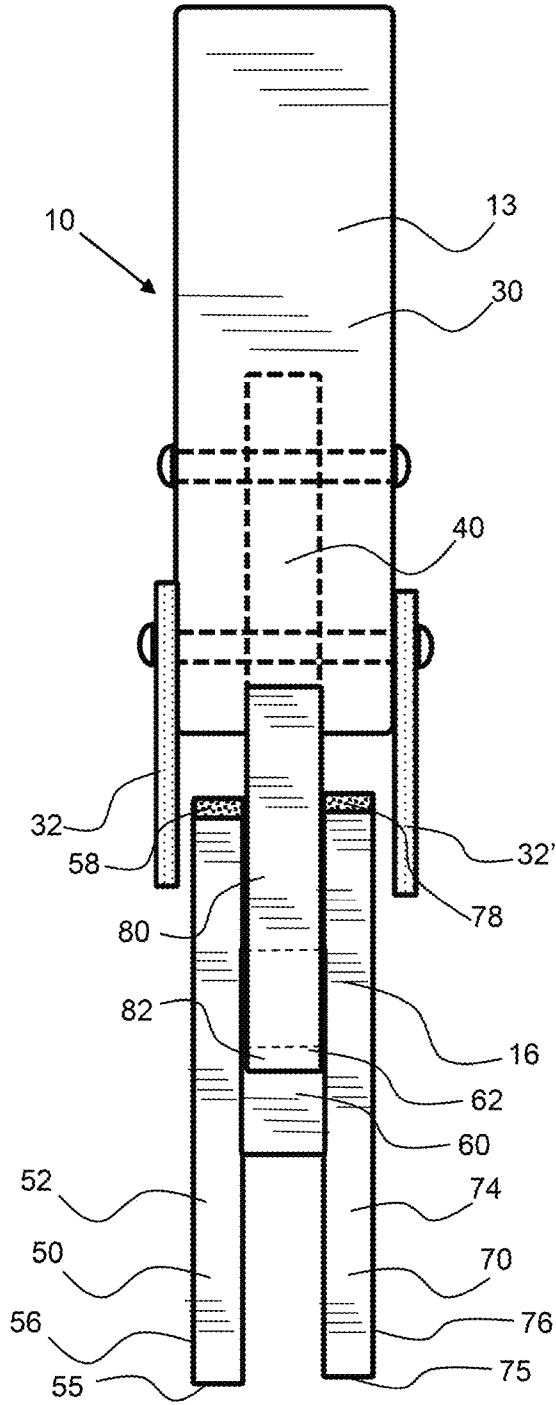

FIG. 3

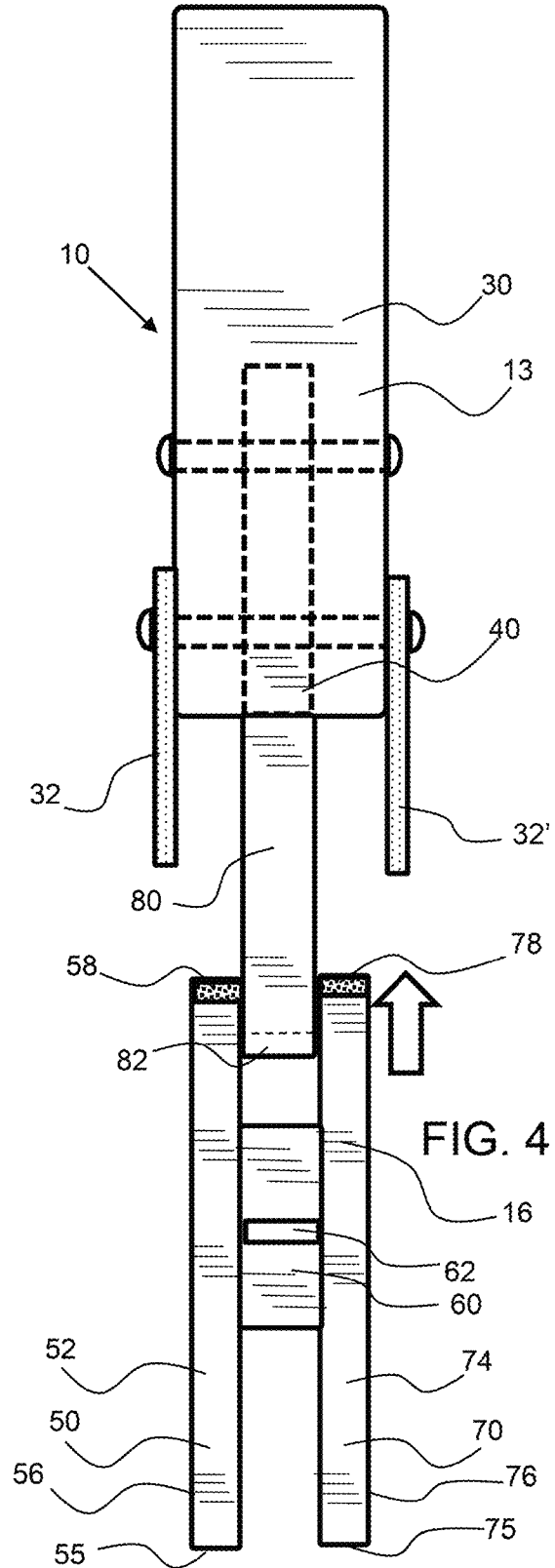
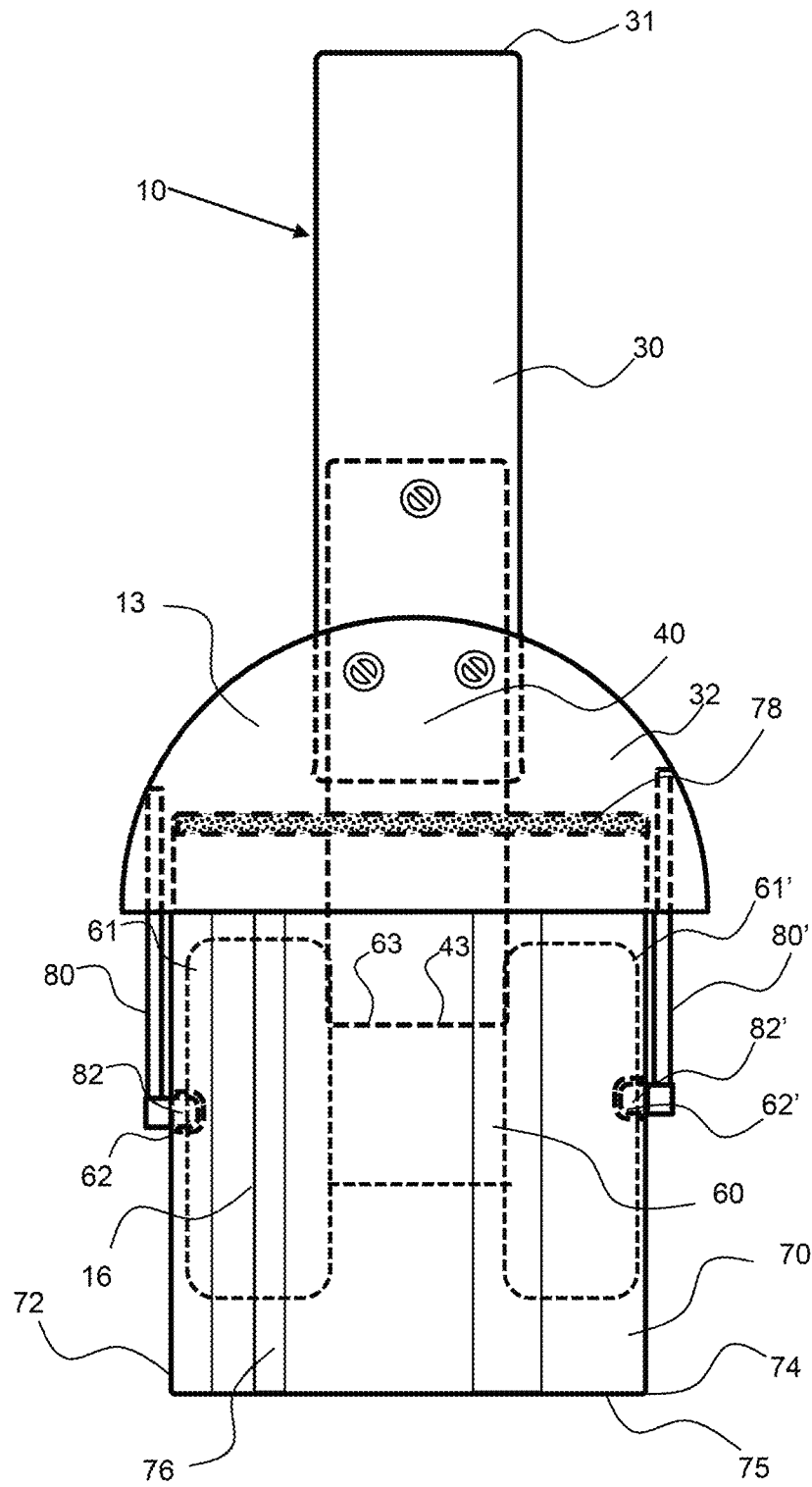

FIG. 4



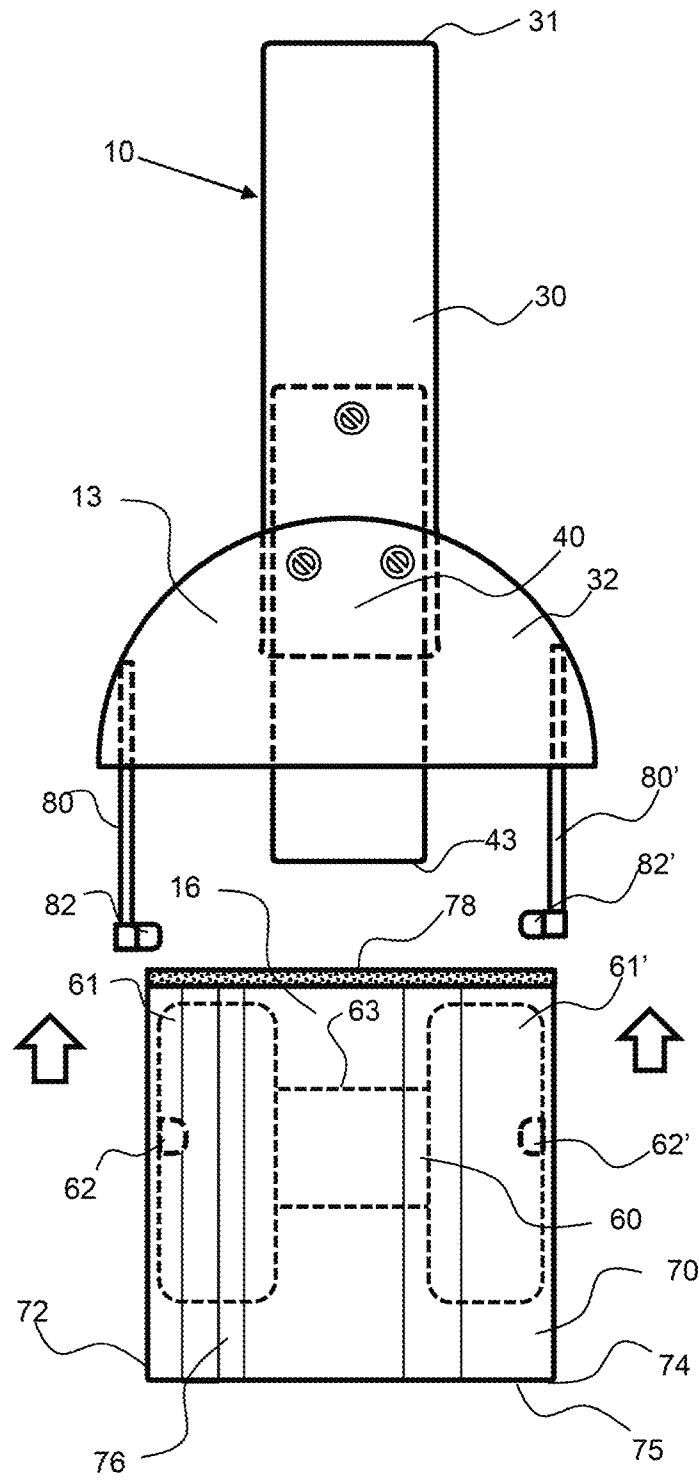

FIG. 6

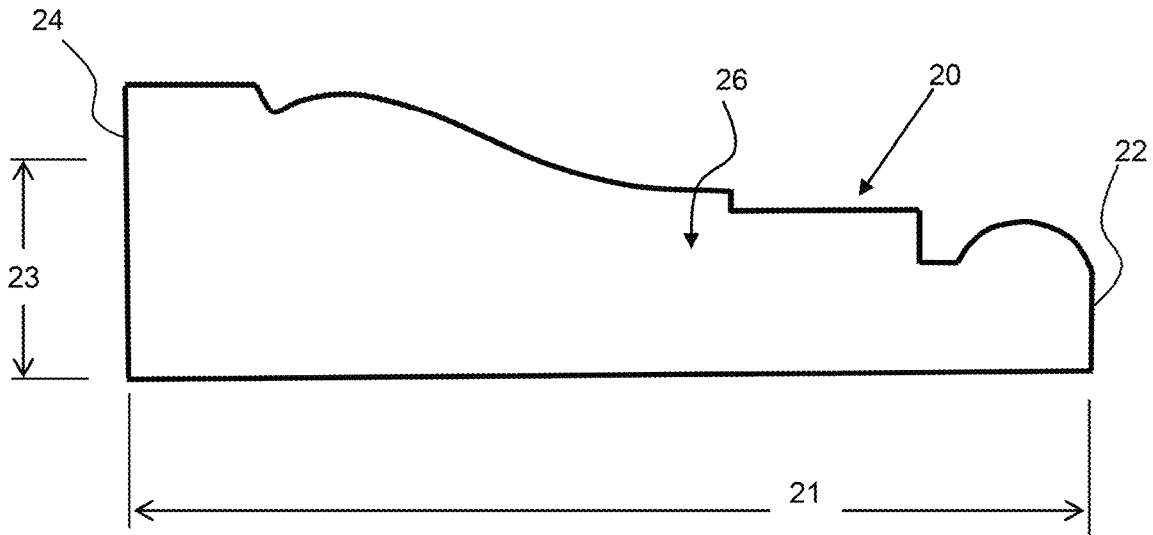

FIG. 7

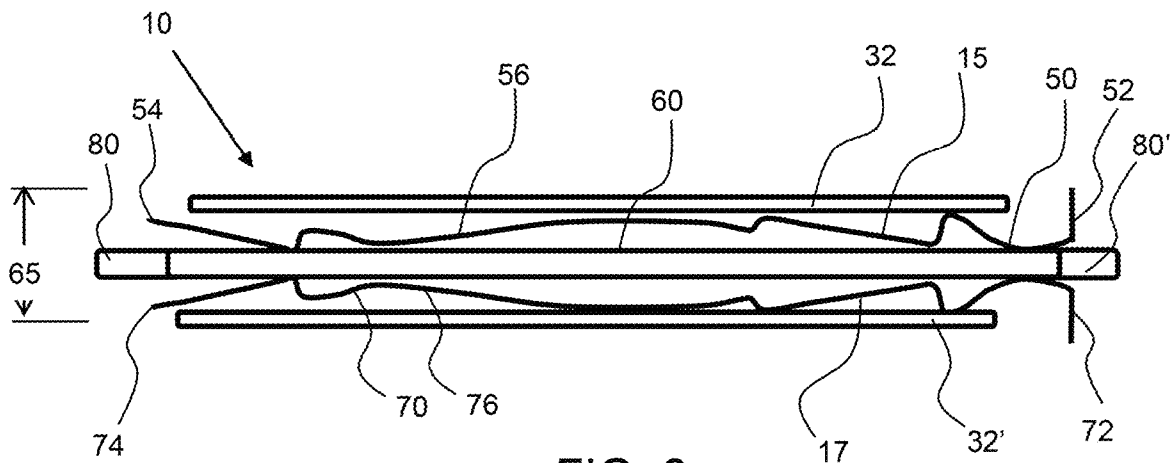

FIG. 8

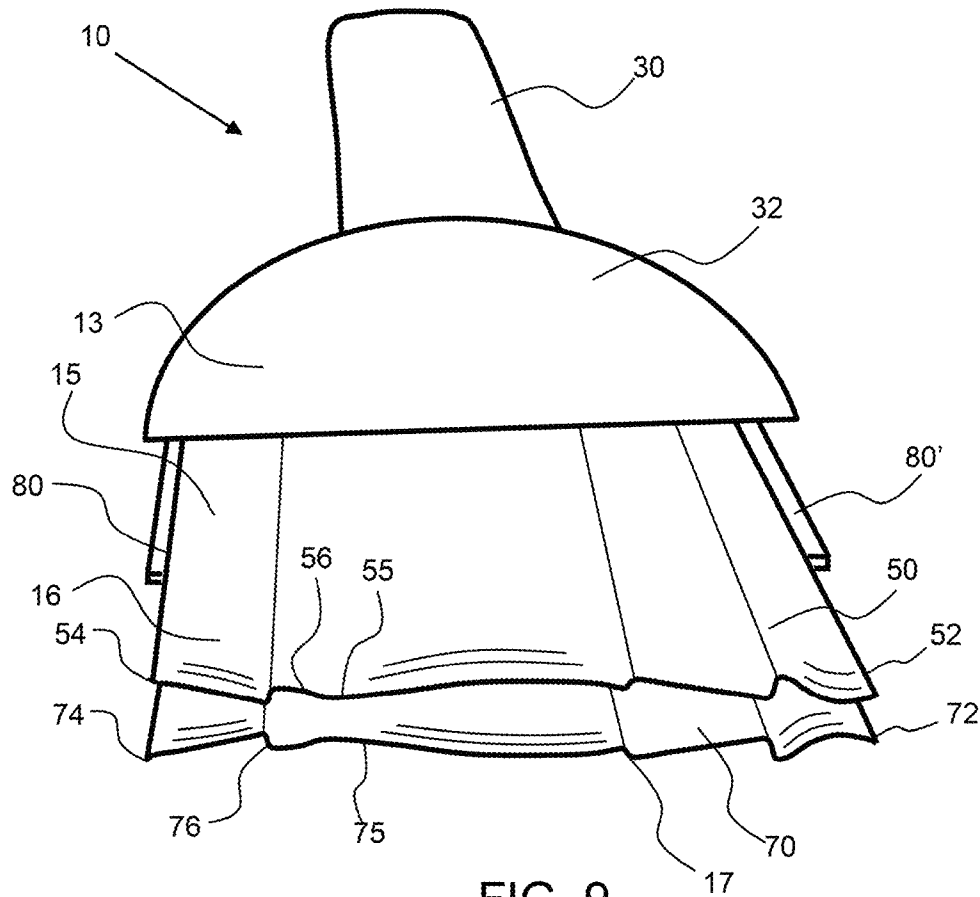

FIG. 9

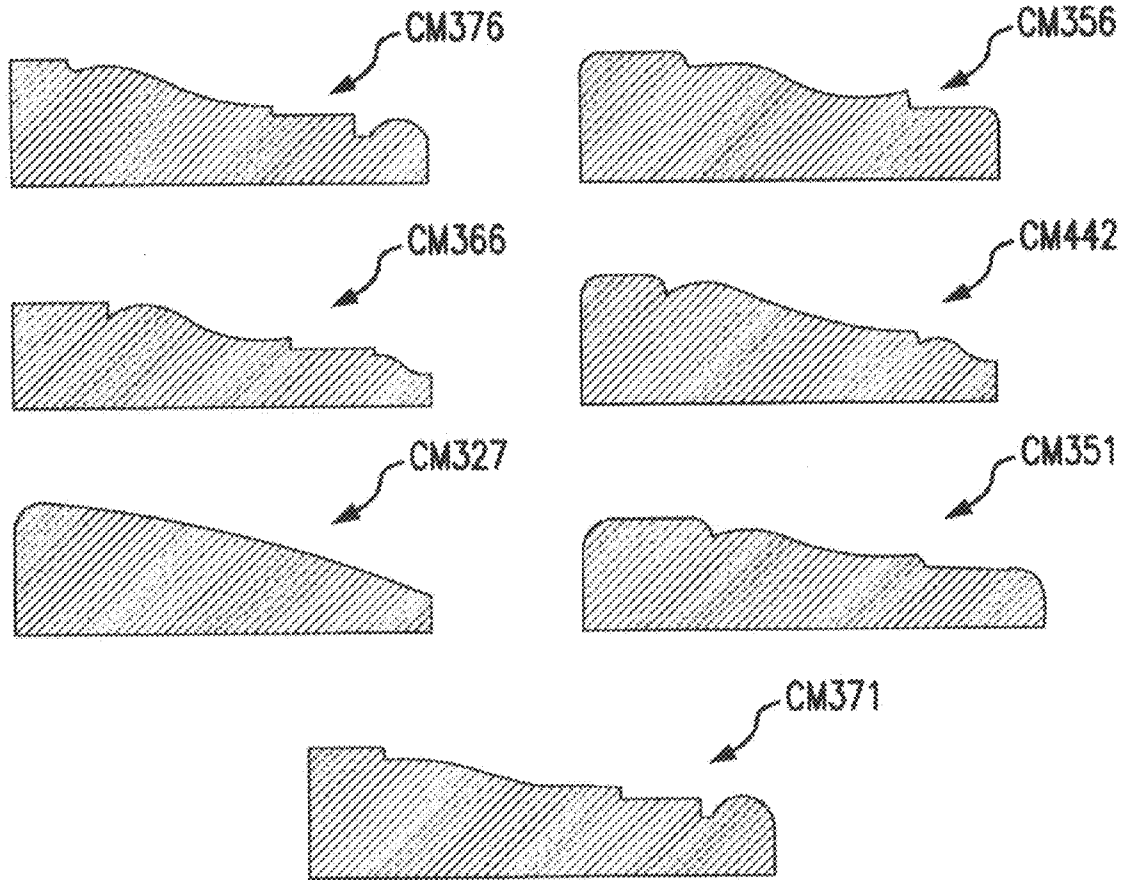

FIG. 10

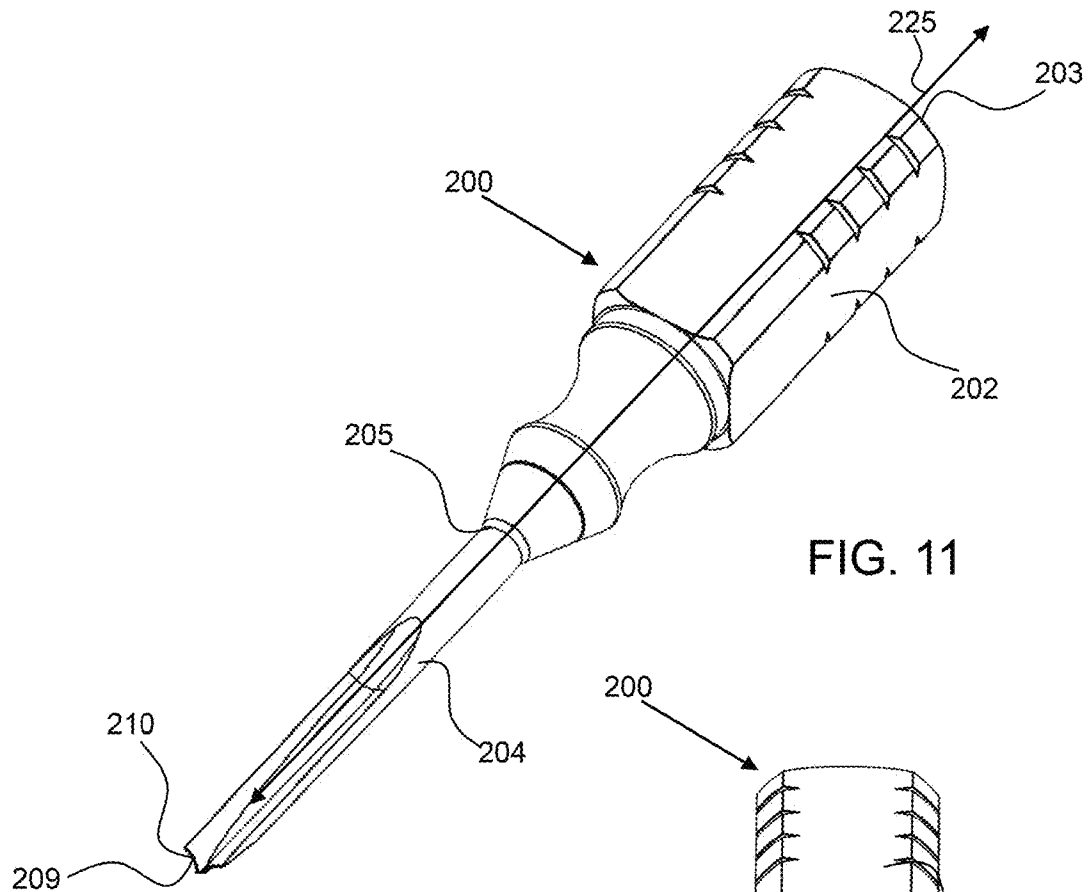

FIG. 11

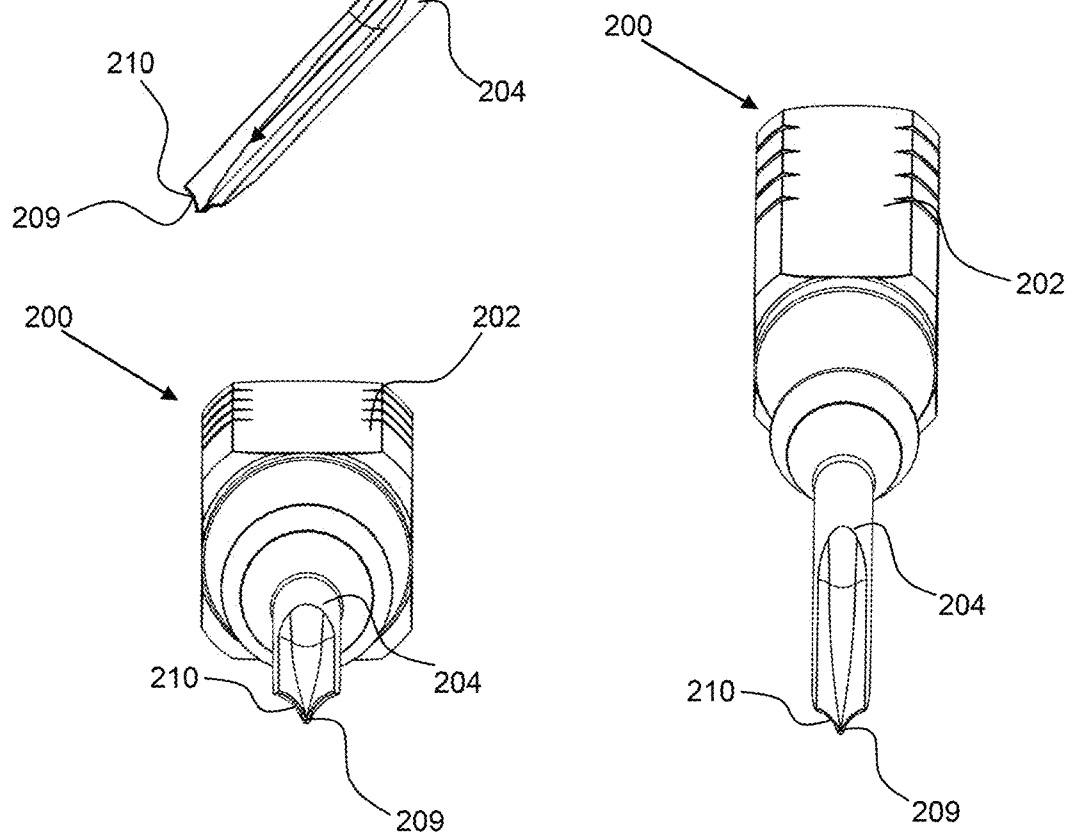
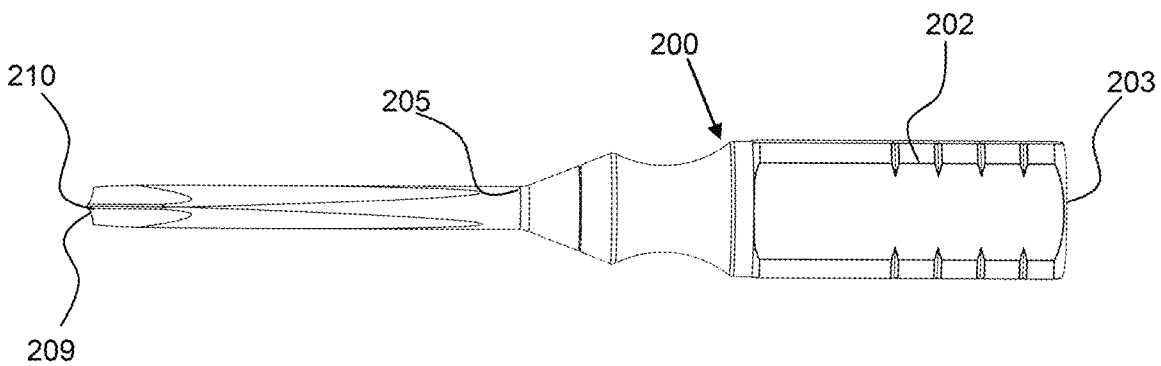
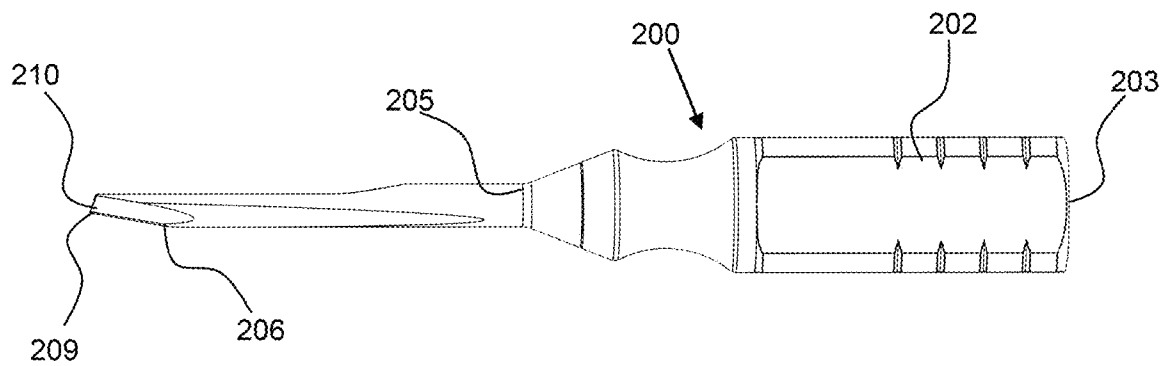
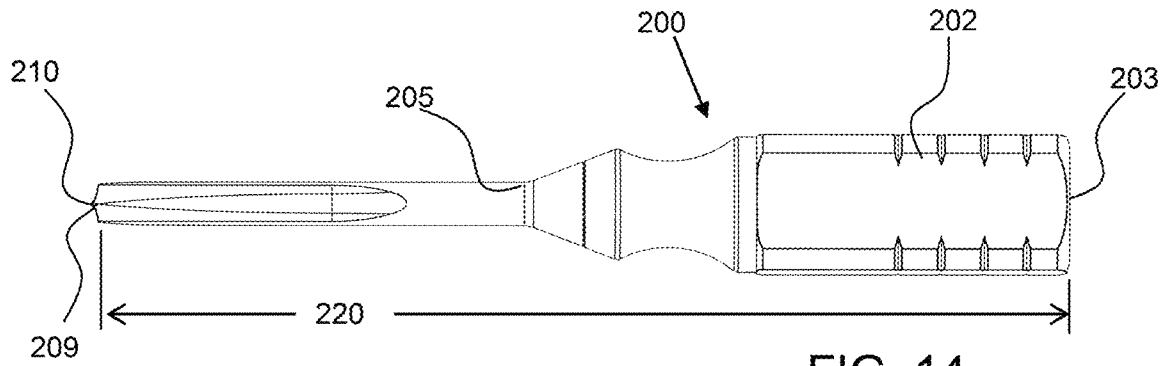

FIG. 12

FIG. 13



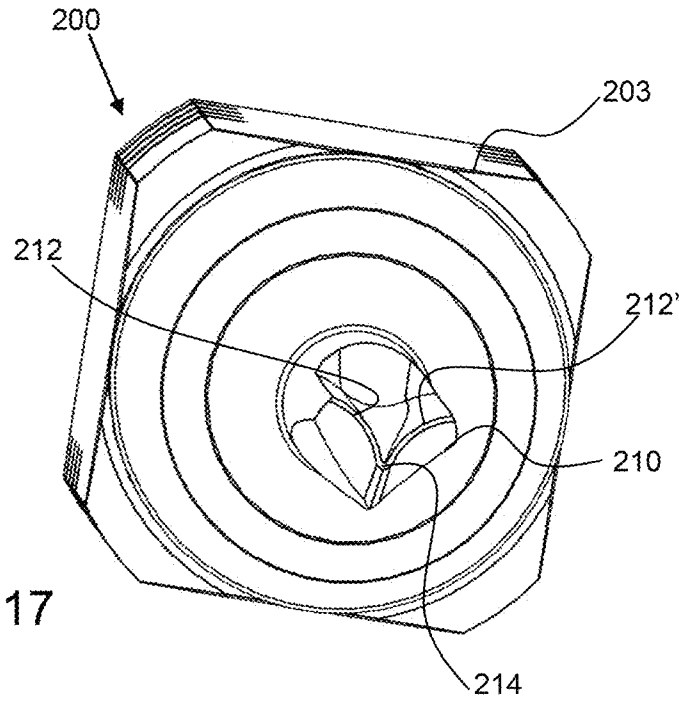

FIG. 17

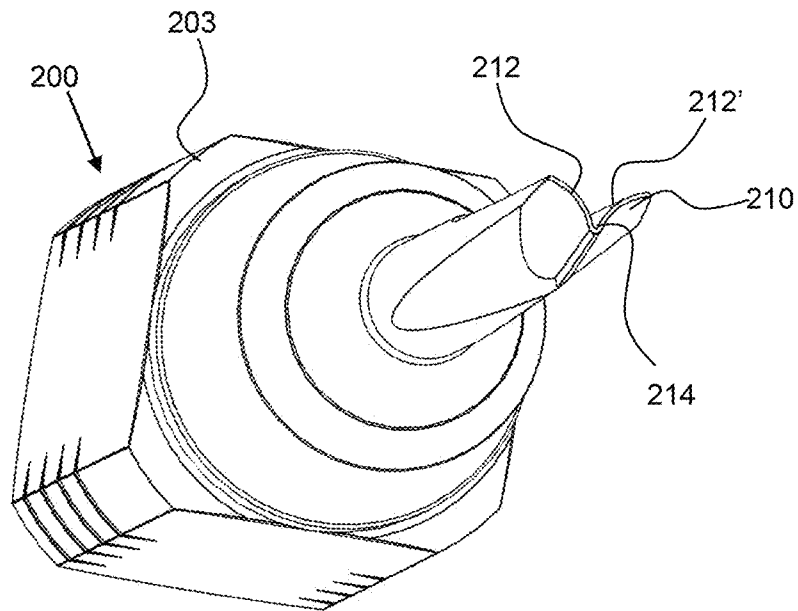

FIG. 18

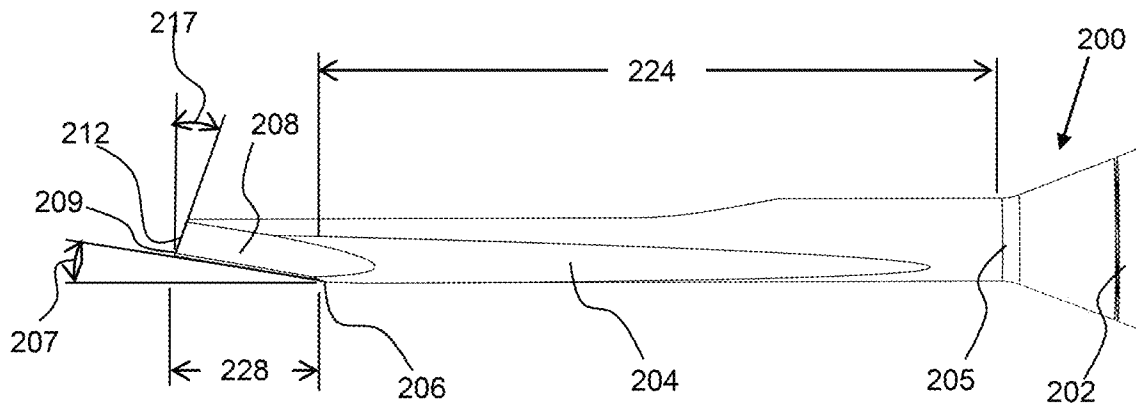

FIG. 19

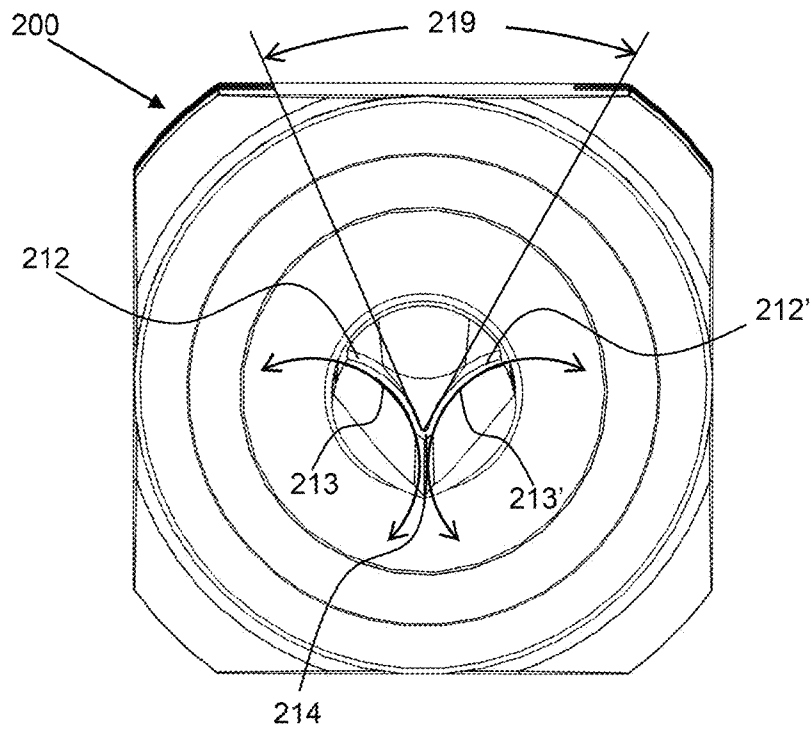
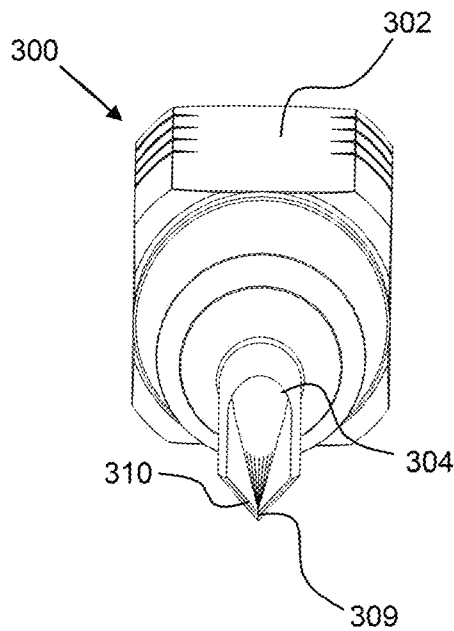
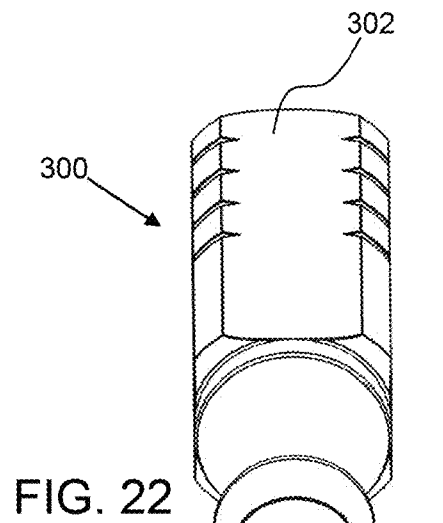
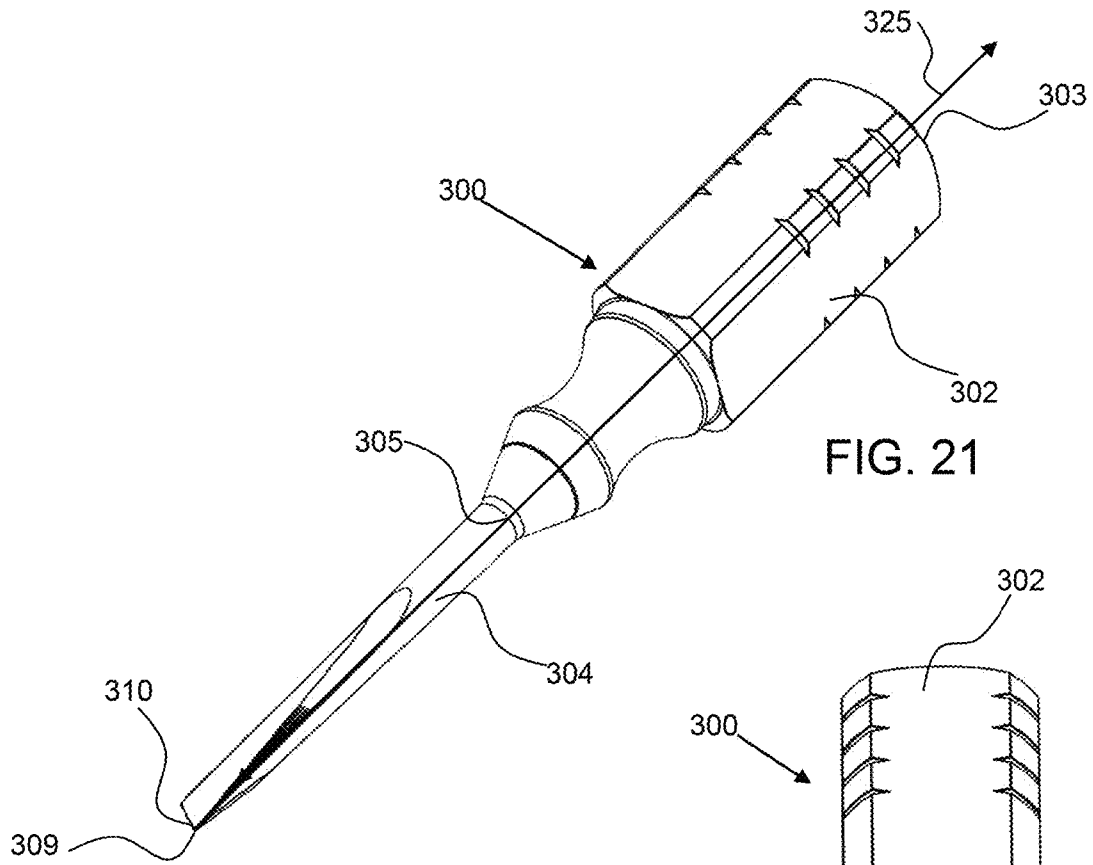

FIG. 20



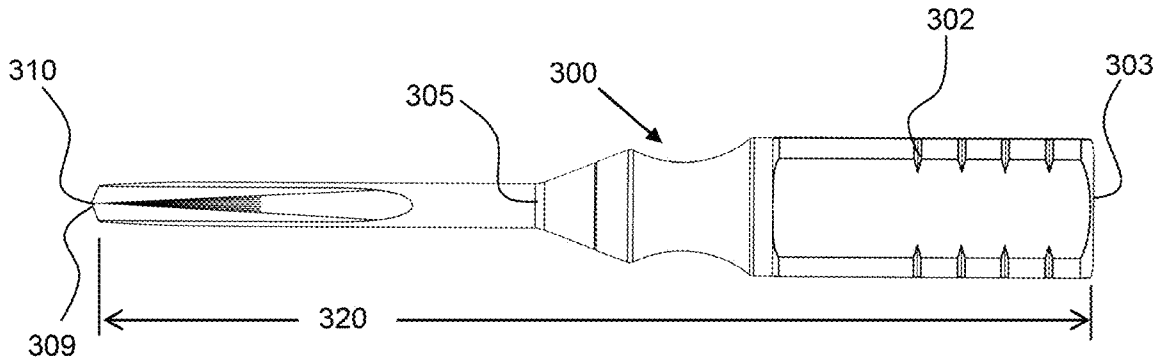

FIG. 24

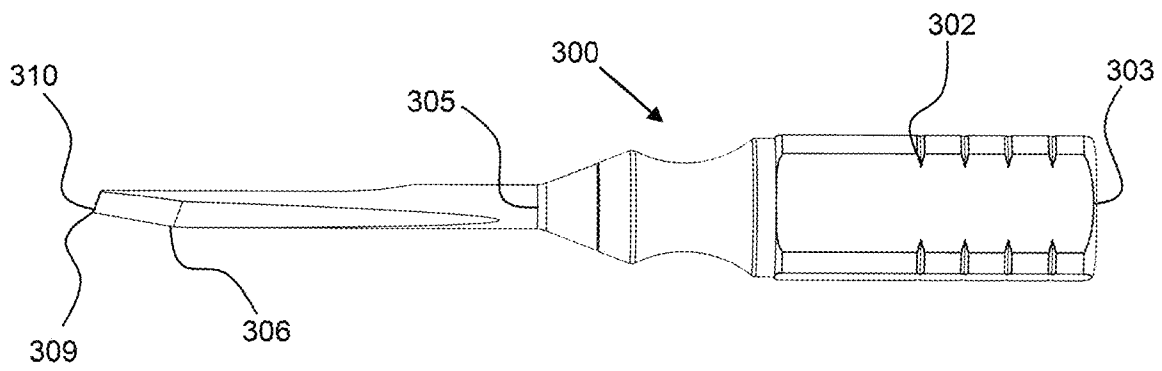

FIG. 25

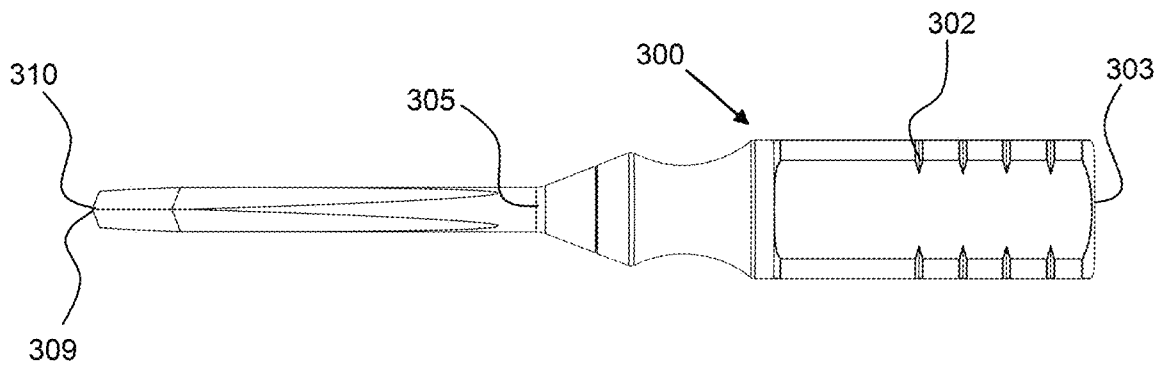
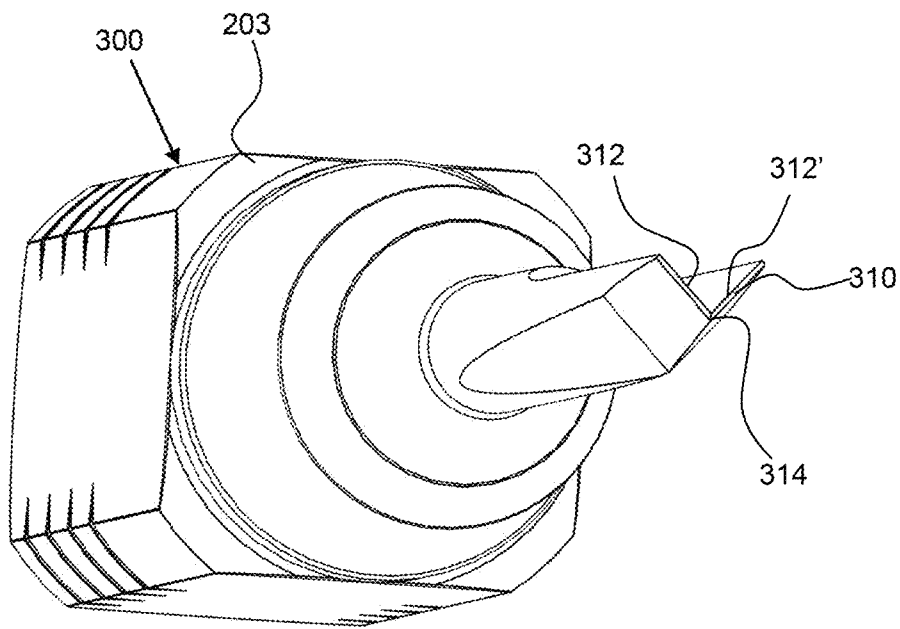
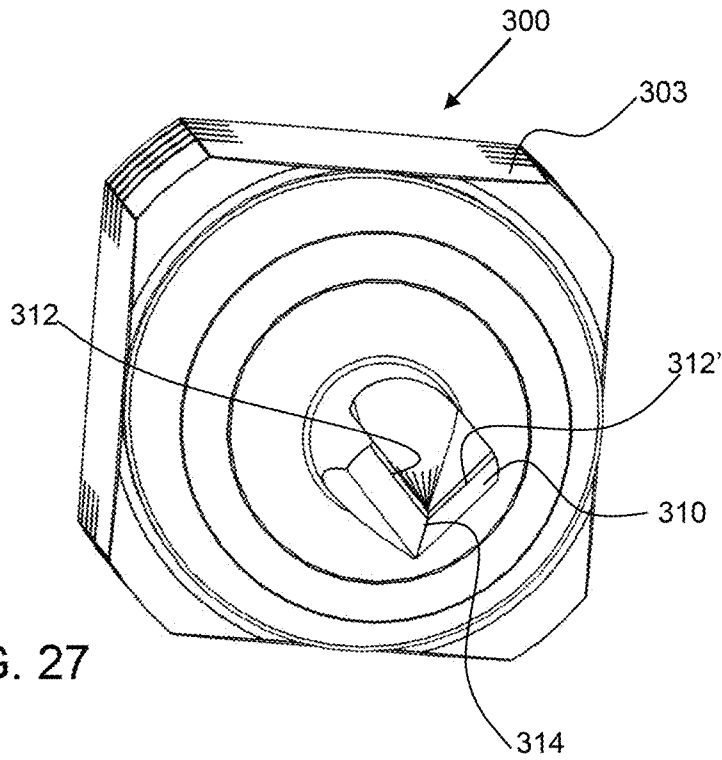

FIG. 26



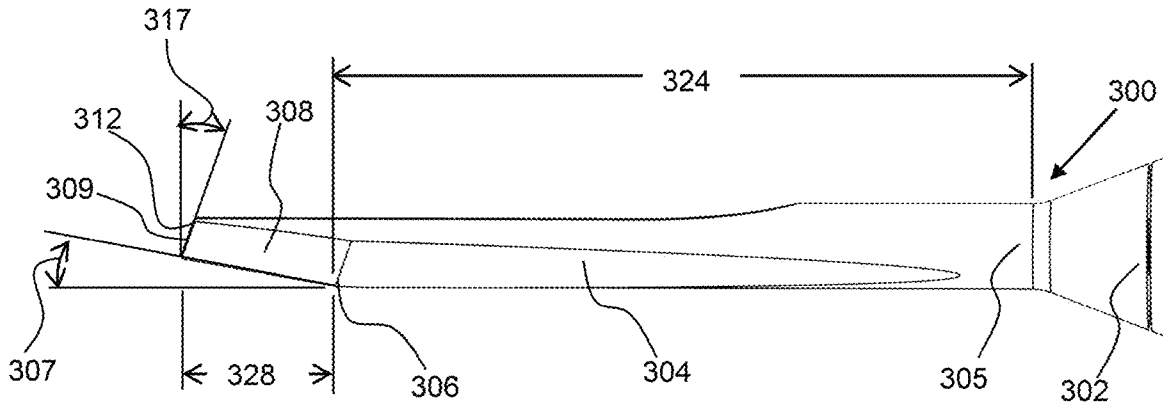

FIG. 29

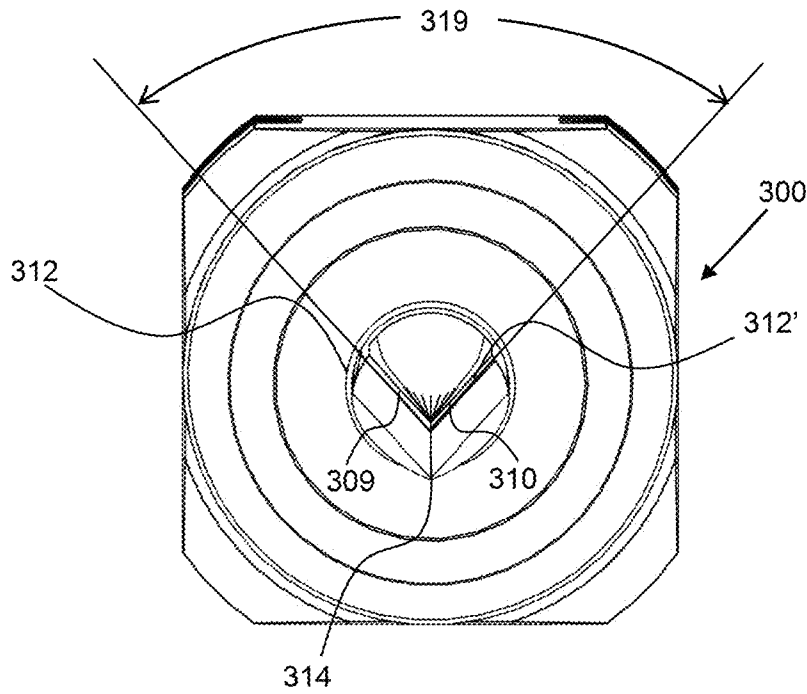

FIG. 30

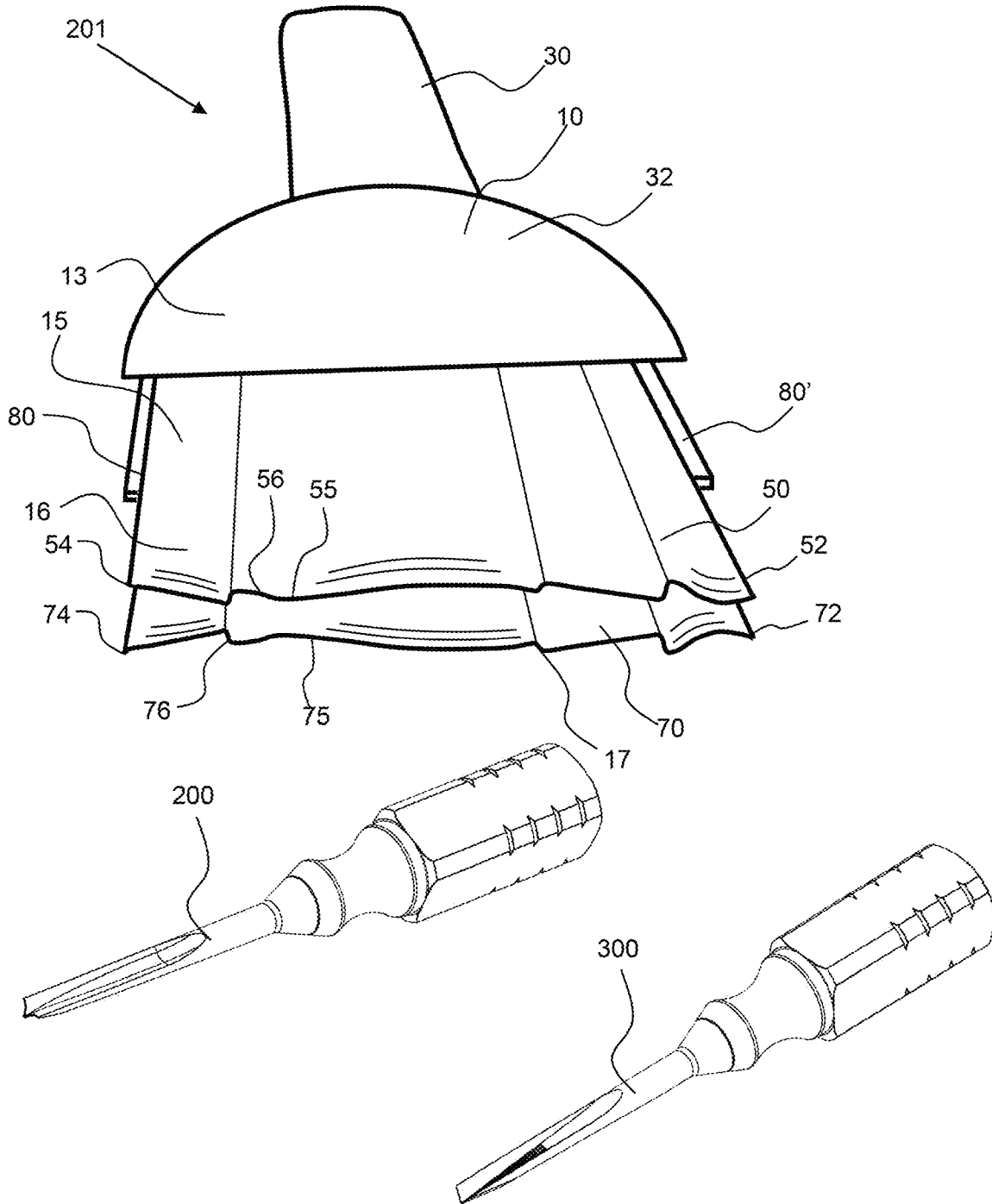

FIG. 31

CASING CHISEL SYSTEM**CROSS REFERENCE TO RELATED APPLICATIONS**

This application is a continuation in part of U.S. patent application Ser. No. 16/922,272, filed on Jul. 7, 2020 and currently pending, which claims the benefit of U.S. provisional patent application No. 62/947,572, filed on Dec. 13, 2019; the entirety of which is incorporated by reference herein.

BACKGROUND OF THE INVENTION**Field of the Invention**

The invention relates to a casing chisel system that includes a two-sided, reversible doorway casing chisel having cutting blades that are mirror images of each other to enable quick cleaning of opposing sides of the vertical casing surrounding a doorway, and a pair of chisels for cleaning within the grooves and edges of the casing, the edge at the baseboard, and the edges of the door jamb surrounding a doorway, wherein one chisel has two straight cutting ends at an acute angle to each other and the other chisel has two curved cutting ends configured at an acute angle to each other.

Background

Debris, paint, sealer, caulk, and the like can collect around the bottom of doorway casing or doorway molding, aka moulding, and is unattractive. Paint for example may run and pool or form bulging globs along the base of the doorway casing molding and the floor. This is difficult to clean and remove as doorway casing molding often has curved and recessed features. In addition, shoe molding may be placed around a doorway casing molding and to enable a proper fit, debris, caulk, paint drips and the like must be removed before installation of the doorway shoe molding.

SUMMARY OF THE INVENTION

The invention is directed to an exemplary casing chisel system that includes a two-sided casing chisel to remove debris along a casing and one or more of a curved detail chisel and/or a straight detail chisel. The system may be provided as a kit including a plurality of two-sided casing chisel to match the contours of various casings and with a plurality of detailed chisels that have different geometries, such as different curves or radius of curvature of the curved chisel edges for the curved detail chisel, or different acute angles of the straight chisel edges for the straight detail chisel. The two-sided casing chisel may be used initially to clean debris from the casing and then the detailed chisel may be used to further clean and remove debris, such as paint or caulk from within and around contours of the casing or baseboard.

A two-sided casing chisel has a curved chisel surface that matches that of the doorway casing contours. Each interior doorway in a home usually consists of vertical casings mounted on each side of the doorway that is connected to the door jamb on the inside and the baseboard against the wall on the wall sides. In an exemplary embodiment, a two-sided casing chisel has two chisel blades that are mirror images of each other to enable one tool for cleaning the doorway casing on either side of the doorway. The two-sided tool is

simply flipped around to allow cleaning of the doorway casing on an opposing side of the doorway.

In addition, the chisel blades may be detachably attached to a handle and may be reversed so that the opposite side of the blades at the contoured ends can be used as either a file or another pair of sharpened chisel blades when reattached to the handle. In other words, an exemplary casing chisel has two pairs of usable blades/files.

An exemplary two-sided casing chisel comprises two components: a handle onto which the chisel blades are attached and a pair of chisel blades that are mirror images of each other and reversible so that each contoured end is usable for chiseling or filing the contoured matched vertical doorway casing. Between a first and second chisel blade may be an H-shaped blade coupler that secures the two blades in place and may serve as a surface to abut with the handle wherein striking the top of the handle with a hammer or mallet imparts a chiseling effect on the blades when placed against the lower end of the casing.

The handle may have an impact end on the top to receive an impact from a hammer or mallet. A user may hold the handle and hit the impact end of the handle to chisel along a doorway casing. Two shields or covers may extend down from the handle and protect the user from being exposed to the opposite sharp ends of the two-sided chisel blade. Blade couplers may extend down from the cover or handle on each side and between the two chisel blades to couple the two-sided chisel blade to the handle and enable detachment and flipping the two-sided chisel blade upside down for re-attachment. The blade couplers may be metal extensions made of spring steel that act as spring elements that are forced outward as the two-sided chisel blade assembly is inserted up into the handle assembly, between the two shields. The blade couplers may have a coupler lock, such as a protrusion on an extended end, that snaps into a recess in the blade support. A user may pull the blade couplers out from the engagement with the blade support to detach the blade assembly from the handle assembly.

A cutting blade may have a curved contour to match that of a doorway casing. A cutting blade on a first side may be the mirror image of the cutting blade on the opposing second side. A user may place the first cutting blade along the first side of the doorway along the doorway casing and after chiseling off debris on the doorway casing on this first side, the tool can be flipped around and aligned so the second cutting blade can be placed against the casing on the opposing second side of the doorway to chisel off debris.

An exemplary two-sided casing chisel has a cutting blade that is contoured to match and interface with a casing, such as any of the commonly used 2.25 inch and 2.50 inch wide casing types depicted in FIG. 10 including, but not limited to, CM376, CM366, CM327, CM356, CM442, CM351, CM371, and any other industry standardized casings. For example, CM376 is 2.25 inches wide with multiple grooves and curves and is also commonly called "Colonial" style. It is currently the most frequently used standardized casing in the building industry and is produced by the majority of manufacturers of casings and moldings. The figures of chisel blades and casing depicted here are contour matched to the CM376 industry standard. In use, a builder may purchase a set of blades specific to the seven casing moldings listed above to insert into the handle, which is designed to secure each for use. Hence, one handle can be used for standardized casings that represent well over 95% of the doorway casings used in the US market today.

This application may be used in conjunction with a Shoe Moulding to Finish an Interior Doorway casing as described

in PCT/US2019/013715 and U.S. Pat. No. 10,676,940 issued on Jun. 9, 2020, to Jim E Fulbrook, the entirety of which is hereby incorporated by reference herein. The invention may also be used independent of the doorway shoe moulding to chisel and sand the ends of the vertical casing to remove excess paint and debris in order to improve the doorway appearance and prepare the casing for painting.

The curved cutting and/or sanding ends of the first side and second side chisel blades are defined as being a non-linear shape and having one or more curved surfaces and in most cases a plurality of curved portions.

An exemplary casing chisel system comprises one or more of a curved detail chisel and or a straight detail chisel. An exemplary detail chisel has a shank that extends from the handle to a chisel arm, along a length axis of the handle, or straight out from the handle. The chisel arm extends from the shank to the cutting end which has the curved chisel or the straight chisel. There is a fulcrum between the shank and the chisel arm, wherein the chisel arm extends at a fulcrum angle from the shank. The length of the shank may be about 50 mm or more, or about 75 mm or more, or about 100 mm or more, or about 125 or even 150 mm or more and any range between and including the length values provided. The length of the chisel arm may be shorter than the length of the shank and may be about half the length of the shank, about a third the length of the shank, a quarter the length of the shank, or even an eighth of tenth the length of the shank and any range between and including the ratios provided. The chisel arm may be about 10 mm or more, about 25 mm or more, about 35 mm or more, about 50 mm or more, about 75 mm or less and any range between and including the length values provided. The ratio of the length of the shank and chisel arm may be configured to provide effective manipulation along a casing, especially when considering the fulcrum angle. The fulcrum angle is the angle of the chisel arm with respect to the shank, or length axis of the shank from the handle, at the fulcrum and may be at least 10 degrees or more, about 20 degrees or more, about 30 degrees or more, about 40 degrees or more, about 50 degrees or less and any range between and including the angles provided. The chisel edges extend at a backset angle from the cutting end which helps to properly align the chisel edge along a surface with the handle offset from the planar surface by the fulcrum angle. The backset angle may be about 2 degrees or more, about 5 degrees or more, about 10 degrees or more, about 20 degrees or more, about 25 degrees or less and any range between and including the angles provided. A preferred range for the backset angle may be from about 5 to 20 degrees. The overall length of the detail chisel from the handle end to the cutting end may be configured to enable hand manipulation along casing mounted to the wall and around a door.

The curved detail chisel has a pair of chisel edges that are curved and may extend in a radius of curvature. The radius of curvature may be about 3 mm or more, about 5 mm or more, about 8 mm or more, about 12 mm or more, about 15 mm or less, or any range between and including the radius of curvature values provided for the curved chisel edges. The length of the curved chisel edges may be about 2 mm or more, about 5 mm or more, about 10 mm or more, about 15 mm or less, or any range between and including the length values provided. The chisel edges are coupled together at the connected portion and extend therefrom at an acute chisel angle that may be about 60 degrees or more, about 70 degrees or more, about 80 degrees or more, but less than 90 degrees and such as from about 60 to 89 degrees.

The connected portion may also extend in a radius of curvature or be curved between the two chisel edges.

The straight detail chisel has a pair of chisel edges that are straight and coupled together at the connected portion and extend therefrom at an acute chisel angle that may be about 60 degrees or more, about 70 degrees or more, about 80 degrees or more, but less than 90 degrees and such as from about 60 to 89 degrees. The length of the chisel edges may be about 2 mm or more, about 5 mm or more, about 10 mm or more, about 15 mm or less, or any range between and including the length values provided.

The summary of the invention is provided as a general introduction to some of the embodiments of the invention and is not intended to be limiting. Additional example embodiments including variations and alternative configurations of the invention are provided herein.

BRIEF DESCRIPTION OF SEVERAL VIEWS OF THE DRAWINGS

The accompanying drawings are included to provide a further understanding of the invention and are incorporated in and constitute a part of this specification, illustrate embodiments of the invention, and together with the description serve to explain the principles of the invention.

FIG. 1 shows an exemplary two-sided casing chisel having a first side chisel blade and an opposing second side chisel blade; wherein the casing chisel blade is contour matched to chisel the doorway casing shown (CM376 industry standard style).

FIG. 2 shows an exemplary two-sided casing chisel having a first side chisel blade and an opposing second side chisel blade; wherein the two-sided casing chisel is rotated 180 degrees to orient the second side chisel blade to the doorway casing shown.

FIGS. 3 and 4 show side views of an exemplary two-sided casing chisel having a two-sided chisel blade consisting of a first side chisel blade and a second side chisel blade, wherein the chisel blades having cutting ends that are mirror images of each other.

FIG. 5 shows a first side view of an exemplary two-sided casing chisel having a handle assembly coupled to a blade assembly.

FIG. 6 shows a first side view of the exemplary two-sided casing chisel shown in FIG. 5, with the blade assembly detached from the handle assembly.

FIG. 7 shows a cross sectional view of a standard CM376 casing having a doorway edge and an extended edge.

FIG. 8 shows a bottom view of an exemplary two-sided casing chisel configured for the standard CM376 casing shown in FIG. 7.

FIG. 9 shows a perspective view of an exemplary two-sided casing chisel configured for the standard CM376 casing shown in FIG. 7.

FIG. 10 shows cross-sections of seven exemplary standard casing profiles with a width of either 2.25 inches or 2.5 inches.

FIG. 11 shows a perspective view of a curved detail chisel having a curved chisel with chisel edges that are curved.

FIG. 12 shows a front perspective view of a curved detail chisel having a curved chisel with chisel edges that are curved.

FIG. 13 shows a front perspective view of a curved detail chisel having a curved chisel with chisel edges that are curved.

FIG. 14 shows a top view of a curved detail chisel having a curved chisel with chisel edges that are curved.

5

FIG. 15 shows a side view of a curved detail chisel having a curved chisel with chisel edges that are curved.

FIG. 16 shows a bottom view of a curved detail chisel having a curved chisel with chisel edges that are curved.

FIG. 17 shows a front-top perspective view of a curved detail chisel having a curved chisel with chisel edges that are curved.

FIG. 18 shows a front-bottom perspective view of a curved detail chisel having a curved chisel with chisel edges that are curved.

FIG. 19 shows a side view of the shank of a curved detail chisel having a curved chisel with chisel edges that are curved.

FIG. 20 shows a front view of the shank of a curved detail chisel having a curved chisel with chisel edges that are curved.

FIG. 21 shows a perspective view of a straight detail chisel having a chisel with straight chisel edges.

FIG. 22 shows a front perspective view of a straight detail chisel having a chisel with straight chisel edges.

FIG. 23 shows a front perspective view of a straight detail chisel having a chisel with straight chisel edges.

FIG. 24 shows a top view of a straight detail chisel having a chisel with straight chisel edges.

FIG. 25 shows a side view of a straight detail chisel having a chisel with straight chisel edges.

FIG. 26 shows a bottom view of a straight detail chisel having a chisel with straight chisel edges.

FIG. 27 shows a front-top perspective view of a straight detail chisel having a chisel with straight chisel edges.

FIG. 28 shows a front-bottom perspective view of a straight detail chisel having a chisel with straight chisel edges.

FIG. 29 shows a side view of the shank of a straight detail chisel having a chisel with straight chisel edges.

FIG. 30 shows a front view of the shank of a straight detail chisel having a chisel with straight chisel edges.

FIG. 31 shows a perspective view of an exemplary casing chisel system comprising a two-sided casing chisel, a curved detail chisel and a straight detail chisel.

Corresponding reference characters indicate corresponding parts throughout the several views of the figures. The figures represent an illustration of some of the embodiments of the present invention and are not to be construed as limiting the scope of the invention in any manner. Further, the figures are not necessarily to scale, some features may be exaggerated to show details of particular components. Therefore, specific structural and functional details disclosed herein are not to be interpreted as limiting, but merely as a representative basis for teaching one skilled in the art to variously employ the present invention.

DETAILED DESCRIPTION OF THE ILLUSTRATED EMBODIMENTS

As used herein, the terms “comprises,” “comprising,” “includes,” “including,” “has,” “having” or any other variation thereof, are intended to cover a non-exclusive inclusion. For example, a process, method, article, or apparatus that comprises a list of elements is not necessarily limited to only those elements but may include other elements not expressly listed or inherent to such process, method, article, or apparatus. Also, use of “a” or “an” are employed to describe elements and components described herein. This is done merely for convenience and to give a general sense of the scope of the invention. This description should be read to

6

include one or at least one and the singular also includes the plural unless it is obvious that it is meant otherwise.

Certain exemplary embodiments of the present invention are described herein and are illustrated in the accompanying figures. The embodiments described are only for purposes of illustrating the present invention and should not be interpreted as limiting the scope of the invention. Other embodiments of the invention, and certain modifications, combinations and improvements of the described embodiments, will occur to those skilled in the art and all such alternate embodiments, combinations, modifications, improvements are within the scope of the present invention.

As shown in FIG. 1, an exemplary two-sided casing chisel 10 has a blade assembly 16 coupled to a handle assembly 13 by the blade coupler springs 80, 80'. The blade assembly has a first side chisel blade 50 and an opposing second side chisel blade 70; wherein the casing chisel blade 70 is oriented to chisel the doorway casing 20 shown. The doorway casing extends from a doorway edge 22 to an extended edge 24 and has a curved outer surface 26. Paint 28 often collects along the base of the casing and is not appealing. The exemplary two-sided casing chisel 10 has the second side chisel blade 70 facing the casing and the second side chisel blade is a mirror image of the first side chisel blade 50 shown. The second side chisel blade has a doorway edge 72 that corresponds with the doorway edge 22 of the casing and an extended edge that corresponds with the extended edge 24 of the casing. The curved outer surface from the doorway edge to the extended edge of the second side chisel blade 70 corresponds with the curved outer surface 26 of the casing. The handle 30 has a coupled end, and an impact end 31, configured to be hit with a hammer or mallet to chisel the doorway casing. The first side chisel blade 50 is a mirror image of the second side chisel blade and has a curved outer surface 56 that extends from a doorway edge 52 to an extended edge 54. The cutting end 55 may be sharp to enable chiseling off the paint or debris from the doorway casing.

As shown in FIG. 2, the exemplary two-sided casing chisel 10 shown in FIG. 1, is now configured in front of the opposing side of the doorway. In order to chisel the opposing casing 22, the two-sided casing chisel 10 must be rotated 180 degrees to present the first side chisel blade to the casing, as indicated by the bold curved arrow. The first side chisel blade 50 corresponds with the casing as shown to enable chiseling off debris along the bottom of the casing. The first side chisel blade has a curved outer surface 56 that matches the curved outer surface 26 of the casing. The first side chisel blade has a doorway edge 52 that corresponds with the doorway edge 22 of the casing and an extended edge 54 that corresponds with the extended edge 24 of the casing. The curved outer surface from the doorway edge to the extended edge of the first side chisel blade 50 corresponds with the curved outer surface 26 of the casing. In effect, the invention conveniently allows for the chiseling of all doorway casings one after the other on opposing sides in a single tool.

As shown in FIGS. 3 to 6, an exemplary two-sided casing chisel 10 has a blade assembly 16 that is detachably attachable to a handle assembly 13. As shown in FIG. 3, the blade assembly is attached to the handle assembly by the blade couplers 80, 80' that extend down between the two blades 50, 70 of the blade assembly and couple with the blade support 60, a support member extending between the two blades. The blade support 60 has coupler attachment recesses 62, 62' configured to receive the coupler locks 82, 82', protrusions extending from the blade couplers 80, 80'. The coupler locks 82, 82' may snap into the coupler attach-

ment recesses **62**, **62'** to secure the blade assembly to the handle assembly as shown in FIGS. **3** and **5**. As shown in FIGS. **4** and **6**, the blade assembly is detached from the handle assembly.

The blade assembly **16** comprises a first side chisel blade **50** and a second side chisel blade **70** coupled together by a blade support **60**, which may be an H-shaped support element as shown in FIGS. **5** and **6**. The blade support may have a receiving aperture **63** for receiving the shaft end **43** of the shaft **40** and coupler attachment recesses **62**, **62'** for receiving the coupler locks **82**, **82'**, respectively, as best shown in FIG. **6**. The shaft **40** may be an extension of the handle **30** or a separate piece that is coupled to the handle. As best shown in FIG. **8**, the blade assembly includes a first side chisel blade **50** and a second side chisel blade **70**, wherein the chisel blades have cutting ends **55**, **75** and curved outer surfaces **56**, **76**, respectively, along the cutting ends that are mirror images of each other.

FIG. **2** shows the doorway cutting edge **52**, of the first side chisel blade and the extended edge **74** of the second side chisel blade is shown in FIGS. **5** and **6**. An exemplary chisel blade may have cutting ends on either end or may have curved sanding ends **58**, **78**, opposing the cutting ends, or optionally a first curved cutting end and a second curved cutting end **55'**, **75'** that enable the blades to be flipped when the first curved cutting end becomes worn. The sanding ends may comprise an abrasive material to enable a user to sand along a doorway casing or the metal chisel blades may be etched with angled parallel cuts that create a filing end. The blade assembly may be simply flipped upside down and attached to the handle assembly for this purpose. As shown in FIG. **3** the blade coupler **80** extends between the two opposing chisel blades **50** and **70** and the coupler lock **82** is retained in the coupler attachment recess **62**. As shown in FIGS. **4** and **6**, the blade assembly **16** is detached from the handle assembly **13**. As shown in FIG. **6**, the blade support **60** has curved upper surfaces **61**, **61'** to enable the shaft end **43** and coupler locks **82**, **82'** to slide into the blade assembly **16** and lock into the recesses **62**, **62'** to secure the blade to the handle.

A handle assembly **13** comprises a handle **30** having an impact end **31** to receive an impact from a hammer or mallet to enable chiseling along a doorway casing. A shaft **40** extends from the handle and may be a separate piece that is attached to the handle. The shaft end **43** is configured to abut the blade support **60** at **63** to exert the chisel load to the blade assembly. Shields **32**, **32'** extend down from the handle to cover the inserted end of the blades **50**, **70**, for safety as they protect the user from being exposed to the sharp opposite ends of the blades. Blade couplers **80**, **80'** extend down from the handle assembly and have coupler locks **82**, **82'**, respectively that are configured to be retained by the blade support **60**. As best shown in FIG. **6**, the blade support is configured with coupler attachment recesses **62**, **62'** for receiving and retaining the coupler locks **82**, **82'**.

As shown in FIG. **7**, a standard CM376 casing **20** has a curved outer surface **26** that extends from a doorway edge **22** that joins the door jamb and an extended edge **24** that abuts with the wall baseboard. The vertical casing may be used along the opening of a doorway. This doorway casing may have a width **21** of about 2.25 inches and a depth **23** of about $\frac{1}{16}$ inch or $\frac{1}{8}$ inch.

Referring now to FIGS. **8** and **9**, an exemplary two-sided casing chisel **10** is configured for the standard CM376 casing shown in FIG. **7**. The two-sided casing chisel has two curved chisel blades **50** and **70** that are configured as mirror images to each other. A first side chisel blade **50** is config-

ured on a first side **15** of the two-sided casing chisel and a second side chisel blade **70** is configured on a second side **17** of the two-sided casing chisel **10**. The first side chisel blade **50** has a curved outer surface **56** extending from a doorway edge **52** and an extended edge **54**. Likewise, the second side chisel blade **70** has curved outer surface **76** extending from a doorway edge **72** and an extended edge **74**. Again, the two curved chisel blades are configured as mirror images to conveniently enable spinning the two-sided casing chisel around to chisel along the casing on opposing sides of a doorway in a single tool. The depth **65** of the exemplary two-sided casing chisel **10** may be small, to prevent any marks made on the floor from being exposed after the addition of a doorway shoe moulding around the casing and door jamb (see U.S. Pat. No. 10,676,940) or when no doorway shoe moulding is used. The shields **32**, **32'** and handle **30** are shown in FIGS. **8** and **9**.

FIG. **10** shows cross-sections of seven exemplary standard casing profiles. Each of these casings have a curved outer surface that has a plurality of interconnected curved sections. The casings are either 2.25 inches or 2.5 inches in width and may be either $\frac{1}{16}$ inch or $\frac{1}{8}$ inch in height on the baseboard ends **52**, **72**. These casings represent about 95% of the current casing market in the U.S. The shields **32**, **32'** are designed with a width greater than 2.5 inches to protect the user from being exposed to the sharp ends of the blades. Wider casings than 2.5 inches are available in the market, which may be available by special order to purchase, but a wider blade shield on the handle will be required for user safety of the casing chisel.

Referring now to FIGS. **11** to **20**, an exemplary detail chisel is a curved detail chisel **200** having a shank **204** extending from a connected end **205**, connected with the handle **202**, to a cutting end **209** having the curved chisel **210**. The shank extends along a length axis **225** of the handle of the detail chisel. The curved chisel **210** has a pair of chisel edges **212**, **212'** that are curved and as shown in FIG. **20**, extend in a radius of curvature **213**, **213'**, respectively. The chisel edges are coupled together at the connected portion **214** and extend therefrom at an acute chisel angle **219**. The connected portion may also extend in a radius of curvature or be curved between the two chisel edges. As shown in FIG. **19**, the chisel edges extend at a backset angle **217** from the cutting end **209** which helps to properly align the chisel edge along a surface with the handle offset from the planar surface by the fulcrum angle **207**. The fulcrum angle is the angle of the chisel arm **208** with respect to the shank **204**, or length axis of the shank from the handle, at the fulcrum **206**. The chisel arm is the extension from the shank. The shank has a length **224** that is longer than the chisel arm length **228**, in this embodiment. The overall length **220** of the curved detail chisel from the handle end **203** to the cutting end **209**, as shown in FIG. **14**, may be configured to enable hand manipulation along casing mounted to the wall and around a door.

Referring now to FIGS. **21** to **30**, an exemplary detail chisel is a straight detail chisel **300** having a shank **304** extending from a connected end **305**, connected with the handle **302**, to a cutting end **309** having the straight chisel **310**. The shank extends along a length axis **325** of the handle of the detail chisel. As shown in FIG. **29**, the chisel edges extend at a backset angle **317** from the cutting end **309** which helps to properly align the chisel edge along a surface with the handle offset from the planar surface by the fulcrum angle **307**. The fulcrum angle is the angle of the chisel arm **308** with respect to the shank **304**, or length axis of the shank from the handle, at the fulcrum **306**. The chisel arm is the

extension from the shank. As shown in FIG. 30, the straight chisel 310 has a pair of chisel edges 312, 312' that are coupled together at the connected portion 314 and extend therefrom at an acute chisel angle 319. The shank has a length 324 that is longer than the chisel arm length 328, in this embodiment. The overall length 320 of the straight detail chisel from the handle end 303 to the cutting end 309, as shown in FIG. 24, may be configured to enable hand manipulation along casing mounted to the wall and around a door.

As shown in FIG. 31, an exemplary casing chisel system 201 comprises a two-sided casing chisel 10, a curved detail chisel 200 and a straight detail chisel 300. As described herein, the casing chisel system may include one of more of the two-sided casing chisels, one or more of the curved detailed chisels and/or one or more of the straight detail chisels. The system may come with a plurality of two-sided casing chisel to match the contours of various casings, as shown in FIG. 10 and with a plurality of detailed chisels that have different geometries, such as different curves or radius of curvature of the curved chisel edges for the curved detail chisel, or different acute angles of the straight chisel edges for the straight detail chisel.

It will be apparent to those skilled in the art that various modifications, combinations and variations can be made in the present invention without departing from the scope of the invention. Specific embodiments, features and elements described herein may be modified, and/or combined in any suitable manner. Thus, it is intended that the present invention cover the modifications, combinations and variations of this invention provided they come within the scope of the appended claims and their equivalents.

What is claimed is:

1. A casing chisel system comprising:

- a) a two-sided casing chisel comprising:
 - i) a first side and an opposing second side;
 - ii) a handle assembly comprising:
 - a handle;
 - a first blade coupler; and
 - a second blade coupler;
 - iii) a blade assembly comprising:
 - a first side chisel blade configured on said first side and comprising:
 - a doorway edge;
 - an extended edge;
 - a first curved cutting end that extends from the doorway edge to the extended edge;
 - a curved contour extending from said cutting end to a second end, opposite said cutting end of said first chisel blade;

wherein the curved cutting end of the first side chisel blade has said curved contour that is a non-linear shape from the doorway edge to the extended edge that is contour matched to a casing;

- a second side chisel blade configured on said second side and comprising:
 - a doorway edge;
 - an extended edge;
 - a first curved cutting end that extends from the doorway edge to the extended edge;
 - a curved contour extending from said cutting end to a second end, opposite said cutting end of said second chisel blade;

wherein the curved cutting end of the second side chisel blade has said curved contour that is a non-linear shape from the doorway edge to the extended edge that is contour matched to said casing;

wherein the curved contour of the curved cutting end of the second side chisel blade is a mirror curved contour of the curved cutting end of the first side chisel blade; and

- iii) a blade support that is configured between and couples the first and second side chisel blades; wherein both the first side chisel blade and the second side chisel blade are attached to and extend from the blade support to the respective cutting edge;

wherein the first blade coupler extends between the first side chisel blade and the second side chisel blade on a doorway edge side of the blade support and the second blade coupler extends between the first side chisel blade and the second side chisel blade on an extended edge side of the blade support, wherein said first blade coupler and second blade coupler each comprise a blade coupler lock configured to detachably attach the handle assembly with the blade assembly; wherein the blade assembly is detachably attachable to the handle assembly; and wherein the handle extends in alignment with the first chisel blade and the second chisel blade;

b) a first detail chisel comprising:

- i) a handle;
- ii) a shank extending from said handle to a chisel arm;
- iii) a fulcrum configured between the shank and the chisel arm producing a fulcrum angle between 10 and 40 degrees;
- iv) a chisel configured on a cutting end of said chisel arm;

wherein the chisel has a pair of chisel edges that extend from a connected portion at an acute chisel angle.

2. The casing chisel system of claim 1, wherein a length of the shank is greater than a length of the chisel arm.

3. The casing chisel system of claim 1, wherein the chisel arm is no more than half the length of the shank.

4. The casing chisel system of claim 1, wherein each of the pair of chisel edges extend back from the cutting end and from on the connected portion at a backset angle between 5 and 20 degrees.

5. The casing chisel system of claim 1, wherein the first detail chisel is a straight detail chisel, wherein each of the pair of chisel edges extend straight from the connected portion.

6. The casing chisel system of claim 1, wherein each of the pair of chisel edges extend back from the cutting end and from on the connected portion at a backset angle between 5 and 20 degrees.

7. The casing chisel system of claim 1, wherein the first detail chisel is a curved detail chisel, wherein each of the pair of chisel edges are curved.

8. The casing chisel system of claim 7, wherein each of the pair of chisel edges extend back from the cutting end and from on the connected portion at a backset angle between 5 and 20 degrees.

9. The casing chisel system of claim 1, wherein the first detail chisel is a curved detail chisel, wherein each of the pair of chisel edges extend in a radius of curvature from the connected portion.

10. The casing chisel system of claim 9, wherein each of the pair of chisel edges extend back from the cutting end and from on the connected portion at a backset angle between 5 and 20 degrees.

11. The casing chisel system of claim 10, wherein the connected portion is curved.

12. The casing chisel system of claim 10, wherein the connected portion extends in a radius of curvature.

11

13. The casing chisel system of claim 1, wherein the shank extends along a length axis of the handle of the first detail chisel.

14. The casing chisel system of claim 1, further comprising a second detail chisel comprising:

- a handle;
 - a shank extending from said handle to a chisel arm;
 - a fulcrum configured between the shank and the chisel arm producing a fulcrum angle between 10 and 40 degrees;
 - a chisel configured on a cutting end of said chisel arm;
- wherein the second detail chisel has a pair of chisel edges that extend from a connected portion at an acute chisel angle; and

wherein said first detail chisel is a straight detail chisel, wherein each of the pair of chisel edges of the first detail chisel extend straight from the connected portion; and

wherein said second detail chisel is a curved detail chisel, wherein each of the pair of chisel edges of the second detail chisel are curved.

12

15. The casing chisel system of claim 14, wherein each of the pair of chisel edges of both the curved detail chisel and the straight detail chisel extend back from the cutting end and from on the connected portion at a backset angle between 5 and 20 degrees.

16. The casing chisel system of claim 1, wherein the blade assembly is detachably attachable to the handle assembly.

17. He casing chisel system of claim 16, further comprising a shaft that extends down from the handle assembly to a shaft end, wherein the shaft end is configured to extend between the first side and second side chisel blades.

18. The casing chisel system of claim 17, wherein the shaft is an extension of the handle.

19. He casing chisel system of claim 17, wherein the blade assembly further comprises a blade support that is configured between and couples the first and second side chisel blades.

20. The casing chisel system of claim 19, wherein the blade support comprises a receiving aperture for receiving the shaft end of the shaft.

* * * * *